

UNIK-II SERIES

100~1800 Ton

- Feature**
- Injection Molding Machine : 100~1800Ton
 - Servo Motor Axis : Max. 5 axis
 - Motion Guide : High Strength and Low noise LM
 - Vertical Arm Structure : Telescopic Arm[2 step]
 - Controller : Body Attached Controller

Power : 1Phase AC220V(50/60Hz)
 Driving Method : Digital Servo Motor
 Control Method : Micro Computer
 Air Pressure : 6 kgf/cm²
 Max. Air Pressure : 8 kgf/cm²
 Chuck Rotation : 90°

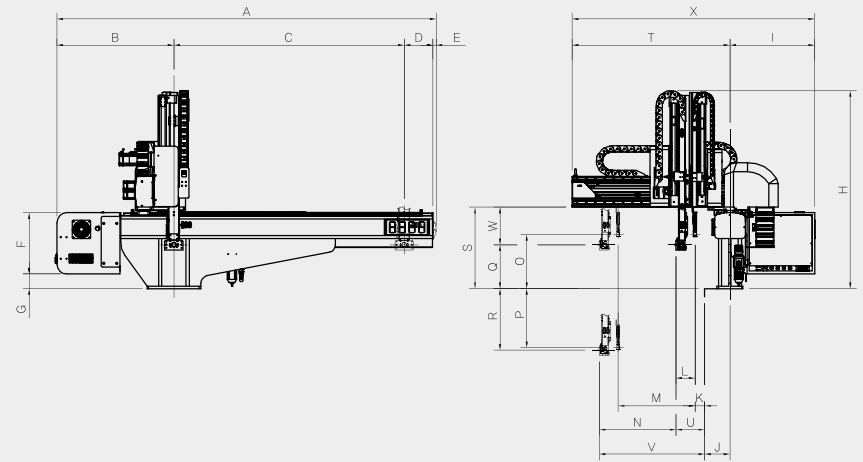
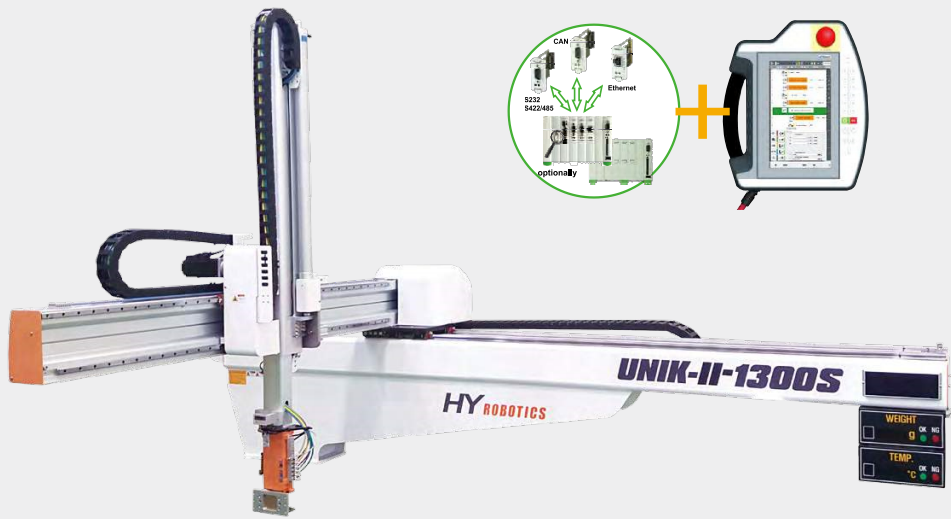

Technical Specification

() is optional.

Model	Traverse (mm)			Vertical (mm)		Crosswise (mm)		Max. Electric Consumption	Air Consumption L (normal)/Cycle	Max. Payload (Chuck Included)	L,M,M (Ton)
	Standard	L-Type	LL-Type	Main Arm	Sub Arm	Main Arm	Sub Arm				
UNIK-II-200S	1500	1700	1900	800	-	640	-	1 Phase / AC 220V S: 9.2A D: 13.3A	6	8 Kgf	100~250
UNIK-II-200D					850	500	500				
UNIK-II-300S	1500	1700	1900	950	-	820	-	1 Phase / AC 220V S: 9.2A D: 13.3A	7	8 Kgf	180~300
UNIK-II-300D					950	680	680				
UNIK-II-400S	1700	2000	-	1100 (1300)	-	940	-	1 Phase / AC 220V S: 9.2A D: 13.3A	7	8 Kgf	280~450
UNIK-II-400D					1100	800	800				
UNIK-II-600S	2000	2200	-	1500	-	1110	-	1 Phase / AC 220V S: 9.2A D: 13.3A	8	10 Kgf	400~650
UNIK-II-600D					1500	960	960				
UNIK-II-800S	2500	-	-	1600	-	1150	-	1 Phase / AC 220V S: 13.0A D: 17.1A	22	15 Kgf	550~900
UNIK-II-800D					1600	960	960				
UNIK-II-1300S	3000	-	-	1800	-	1585	-	1 Phase / AC 220V 13.0A	25	18 Kgf	1000~1800

All information subject to change without notice for quality improvements.

Dimension

Unit : mm / ()mark signify L-Type, []mark signify LL-Type.

Model	A	B	C	D	E	F	G	H	I	J	K	L	M	N	O	P	Q	R	S	T	U	V	W	X
UNIK-II-200S	2470 (2670)	762	1500 (1700)	188	20	400	95	1288	552	165	-	-	-	640	-	-	286	514	530	1027	46	686	244	1579
UNIK-II-200D	[2870]		[1900]	62	124	500	500	353	498	-	-	-	-	-	-	-	-	-	-	-	-	186	-	-
UNIK-II-300S	2470 (2670)	762	1500 (1700)	188	20	400	95	1388	552	165	-	-	-	820	-	-	286	664	530	1027	46	686	244	1759
UNIK-II-300D	[2870]		[1900]	62	124	680	680	353	598	-	-	-	-	-	-	-	-	-	-	-	-	186	-	-
UNIK-II-400S	2714 (3014)	762	1700 (2000)	188	65	400	95	1438	552	165	-	-	-	940	-	-	138	962	530	1327	46	986	392	1879
UNIK-II-400D	[2000]		[2000]	62	124	800	800	209	891	-	-	-	-	-	-	-	-	-	-	-	-	186	-	-
UNIK-II-600S	3025 (3225)	782	2000 (2200)	138	105	400	197	1747	552	165	-	-	-	1110	-	-	178	1322	632	1487	46	1151	454	2039
UNIK-II-600D	[2200]		[2200]	62	129	960	960	228	1272	-	-	-	-	-	-	-	-	-	-	-	-	191	-	-
UNIK-II-800S	3710	855	2500	335	21	400	229	1986	581	235	-	-	-	1150	-	-	84	1516	620	1686	99	1249	536	2267
UNIK-II-800D											102	187	960	960	130	1470	-	-	-	-	-	-	-	-
UNIK-II-1300S	4201	780	3000	320	102	400	476	2125	605	265	-	-	-	1585	-	-	140	1661	755	2155	124	1709	616	2761

All information subject to change without notice for quality improvements.