

UNIK SERIES

30~650 Ton

- Feature**
- Injection Molding Machine : 30~450Ton
 - Servo Motor Axis : Max. 5 axis
 - Motion Guide : High Strength and Low noise LM
 - Vertical Arm Structure : Non Telescopic Arm
 - Controller : Body Attached Controller

Power : 1Phase AC220V(50/60Hz)
 Driving Method : Digital Servo Motor
 Control Method : Micro Computer
 Air Pressure : 6 kgf/cm²
 Max. Air Pressure : 8 kgf/cm²
 Chuck Rotation : 90°

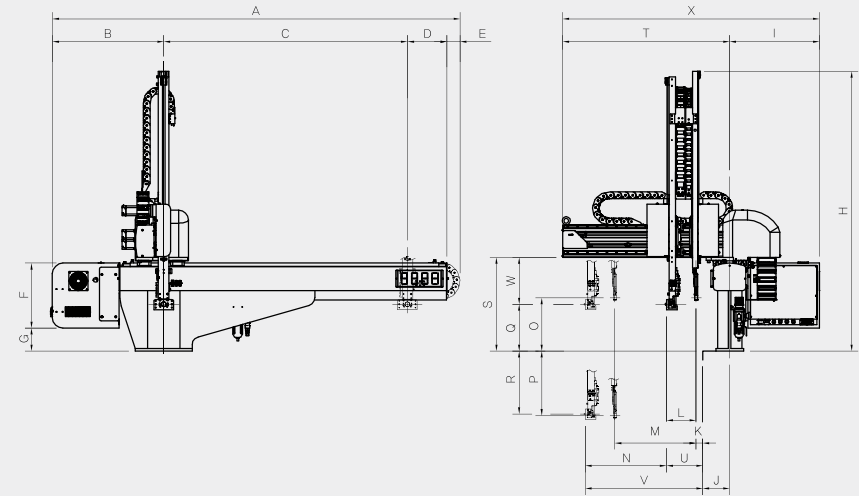
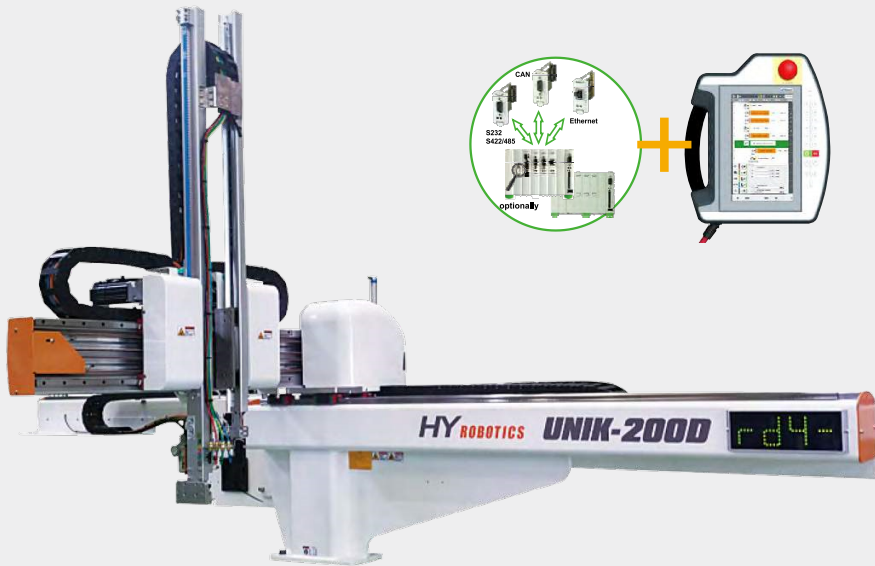

Technical Specification

Model	Traverse (mm)			Vertical (mm)		Crosswise (mm)		Max. Electric Consumption	Air Consumption [ℓ (normal)/Cycle]	Max. Payload (Chuck Included)	L.M.M (Ton)
	Standard	L-Type	LL-Type	Main Arm	Sub Arm	Main Arm	Sub Arm				
UNIK-80S	1200	1400	-	650	-	585	-	1 Phase / AC 220V S: 6.8A D: 10.9A	6	3 kgf	30~80
UNIK-80D				700	450	450					
UNIK-200S	1500	1700	1900	800	-	660	-	1 Phase / AC 220V S: 6.8A D: 10.9A	6	5 kgf	100~250
UNIK-200D				850	500	500					
UNIK-300S	1500	1700	1900	950	-	835	-	1 Phase / AC 220V S: 6.8A D: 10.9A	7	5 kgf	180~300
UNIK-300D				950	675	675					
UNIK-400S	1700	2000	-	1100	-	835	-	1 Phase / AC 220V S: 6.8A D: 10.9A	7	5 kgf	280~450
UNIK-400D				1100	675	675					

All information subject to change without notice for quality improvements.

Dimension

Unit : mm / () mark signify L Type, [] mark signify LL type.

Model	A	B	C	D	E	F	G	H	I	J	K	L	M	N	O	P	Q	R	S	T	U	V	W	X
UNIK-80S	2114 (2314)	600	1200 (1400)	218	96	350	234	1356	442	100	-	-	-	585	-	-	150	500	419	928	80 215	665	269	1370
UNIK-80D											81	134	450	450	175	526	288	512	576	1027	64 224	724	288	1579
UNIK-200S	2509 (2709)	686	1500 (1700)	244	80	400	141	1722	552	165	-	-	-	660	-	-	288	512	576	1027	64 224	724	288	1579
UNIK-200D											42	182	500	500	328	522	288	662	576	1207	64 224	899	288	1759
UNIK-300S	2509 (2709)	686	1500 (1700)	244	80	400	141	1822	552	165	-	-	-	835	-	-	288	662	576	1207	64 224	899	288	1759
UNIK-300D											42	182	675	675	328	622	288	662	576	1207	64 224	899	288	1759
UNIK-400S	2714 (3014)	686	1700 (2000)	244	85	400	141	1972	552	165	-	-	-	835	-	-	288	812	576	1207	64 224	899	288	1759
UNIK-400D											42	182	675	675	328	772	288	812	576	1207	64 224	899	288	1759

All information subject to change without notice for quality improvements.