

NEXIA-V SERIES

100~1300 Ton (for automation / high-precision type)

Power : 1Phase/3Phase AC220V(50/60Hz)
 Driving Method : Digital Servo Motor
 Control Method : Micro Computer
 Air Pressure : 6 kgf/cm²
 Max. Air Pressure : 8 kgf/cm²
 Chuck Rotation : 90°

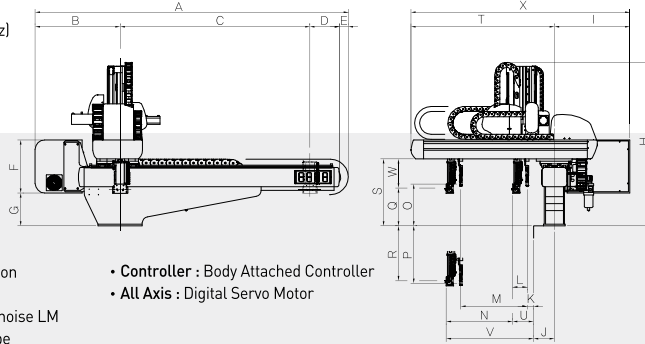

Feature

- Injection Molding Machine : 100~1300Ton
- Servo Motor Axis : Max. 7 axis
- Motion Guide : High Strength and Low noise LM
- Crosswise Frame : Double Support Type
- Vertical Arm Structure : Telescopic Arm(2 step)

- Controller : Body Attached Controller
- All Axis : Digital Servo Motor

Dimension

Unit : mm / () mark signify L Type, [] mark signify LL type.

Model	A	B	C	D	E	F	G	H	I	J	K	L	M	N	O	P	Q	R	S	T	U	V	W	X
NEXIA-V-200S	2557 (2757)	745	1500 (1700)	275	37	400	280	1318	556	165	-	-	-	634	-	-	286	514	530	1135	52	686	244	1691
NEXIA-V-200D	[2957]		[1900]								62	124	500	500	346	504								
NEXIA-V-300S	2557 (2757)	745	1500 (1700)	275	37	400	280	1397	556	165	-	-	-	814	-	-	286	664	530	1315	186	866	244	1871
NEXIA-V-300D	[2957]		[1900]								62	124	680	680	346	604								
NEXIA-V-400S	2780 (3080)	785	1700 (2000)	295	-	400	314	1668	581	205	-	-	-	1050	-	-	258	842	632	1626	51	1106	374	2207
NEXIA-V-400D	[3080]		[2000]								86	170	850	850	340	760								
NEXIA-V-600S	3120 (3620)	785	2000 (2500)	335	-	400	444	1908	606	235	-	-	-	1085	-	-	291	1009	753	1719	98	1183	462	2325
NEXIA-V-600D	[3620]		[2500]								72	237	875	875	347	953								
NEXIA-V-800S	3705 (4205)	825	2500 (3000)	380	-	500	485	2331	811	255	-	-	-	1160	-	-	368	1232	927	1873	127	1287	559	2684
NEXIA-V-800D	[4205]		[3000]								69	259	960	960	428	1172								
NEXIA-V-1300S	4502 (5002)	963	3000 (3500)	523	17	-	-	2657	866	290	-	-	-	1550	-	-	361	1439	1092	2546	286	1836	731	3412
NEXIA-V-1300D	[5002]		[3500]								85	341	1410	1410	397	1403								

Technical Specification

() is optional.

Model	Traverse (mm)			Vertical (mm)		Crosswise (mm)		Max. Electric Consumption	Air Consumption [ℓ (normal)/Cycle]	Max. Payload (Chuck Included)	I.M.M (Ton)
	Standard	L-Type	LL-Type	Main Arm	Sub Arm	Main Arm	Sub Arm				
NEXIA-V-200S	1500	1700	1900	800 (950)	-	634	-	1Phase / AC 220V S: 11.6A / D: 15.7A	7	8 Kgf	100~250
NEXIA-V-200D				850 (950)	500	500					
NEXIA-V-300S	1500	1700	1900	950	-	814	-	1Phase / AC 220V S: 11.6A / D: 15.7A	7	8 Kgf	180~300
NEXIA-V-300D				950	680	680					
NEXIA-V-400S	1700	2000	-	1100	-	1050	-	1Phase / AC 220V S: 11.6A / D: 15.7A	16	10 Kgf	280~450
NEXIA-V-400D				1100	850	850					
NEXIA-V-600S	2000	2500	-	1300	-	1085	-	1Phase / AC 220V S: 11.6A / D: 15.7A	22	15 Kgf	400~650
NEXIA-V-600D				1300	875	875					
NEXIA-V-800S	2500	3000	-	1600	-	1160	-	3Phase / AC 220V S: 8.5A / D: 10.8A	35	20 Kgf	550~900
NEXIA-V-800D				1600	960	960					
NEXIA-V-1300S	3000	3500	-	1800	-	1550	-	3Phase / AC 220V S: 11.4A / D: 15.2A	56	30 Kgf	1000~1300
NEXIA-V-1300D				1800	1410	1410					

All information subject to change without notice for quality improvements.

NEXIA-E SERIES

400S~2000 Ton (slim type)

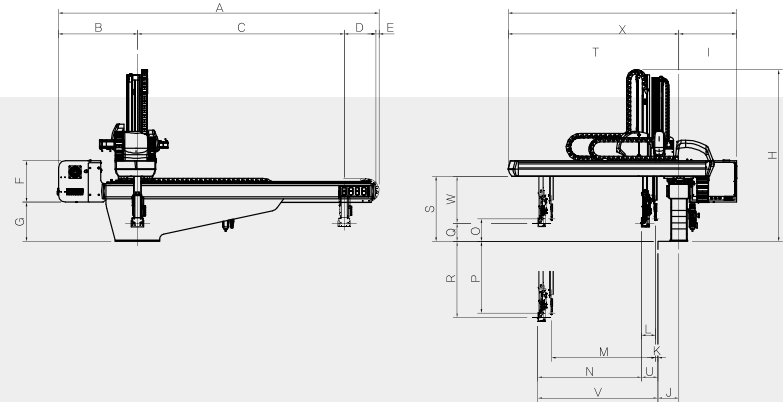

Feature

- Injection Molding Machine : 400~2000Ton
- Servo Motor Axis : Max. 7 axis
- Motion Guide : High Strength and Low noise LM
- Crosswise Frame : Double Support Type
- Vertical Arm Structure : Telescopic Arm(2 step)
- Controller : Body Attached Controller
- All Axis : Digital Servo Motor

Power : 1Phase/3Phase AC220V(50/60Hz)
 Driving Method : Digital Servo Motor
 Control Method : Micro Computer
 Air Pressure : 6 kgf/cm²
 Max. Air Pressure : 8 kgf/cm²
 Chuck Rotation : 90°

Dimension

Unit : mm / () mark signify L Type.

Model	A	B	C	D	E	F	G	H	I	J	K	L	M	N	O	P	Q	R	S	T	U	V	W	X
NEXIA-E-600S	3102	765	2000	305	32	400	382	1662	556	205	-	-	-	1110	-	-	178	1122	632	1653	52	1162	454	2209
NEXIA-E-600D											22	135	1005	1005	221	1079								
NEXIA-E-800S	3580	785	2500	295	-	400	314	1955	581	235	-	-	-	1150	-	-	81	1519	632	1806	98	1248	550	2387
NEXIA-E-800D											57	173	1019	1019	126	1474					230			
NEXIA-E-1300S	4145	770	3000	375	-	400	444	2199	606	255	-	-	-	1585	-	-	139	1662	753	2259	122	1707	615	2865
NEXIA-E-2000S	4765	825	3500	440	-	400	545	2593	631	290	-	-	-	1640	-	-	179	1921	927	2548	287	1927	748	3179

Technical Specification

() is optional.

Model	Traverse (mm)	Vertical (mm)		Crosswise (mm)		Max. Electric Consumption	Air Consumption [ℓ (normal)/Cycle]	Max. Payload (Chuck Included)	I.M.M (Ton)
		Main Arm	Sub Arm	Main Arm	Sub Arm				
NEXIA-E-600S	2000	1300 (1500)		1110	-	1Phase / AC 220V S: 11.6A / D: 15.7A	16	10 Kgf	400~650
NEXIA-E-600D				1005	1005				
NEXIA-E-800S	2500	1600 (1800)		1150	-	1Phase / AC 220V S: 11.6A / D: 15.7A	22	15 Kgf	550~900
NEXIA-E-800D				1019	1019				
NEXIA-E-1300S	3000	1800		1585	-	1Phase / AC 220V 11.6A	25	18 Kgf	1000~1300
NEXIA-E-2000S	3500	2100		1640	-	3Phase / AC 220V 8.5A	38	30 Kgf	1500~2000

All information subject to change without notice for quality improvements.